



*An Online PDH Course  
brought to you by  
CEDengineering.com*

## **Structural Design of Temporary Structural Supports for Existing Structures**

Course No: S02-034

Credit: 2 PDH

---

Ibrahim M. Metwally, Ph.D., P.E.

---



Continuing Education and Development, Inc.

P: (877) 322-5800

[info@cedengineering.com](mailto:info@cedengineering.com)

**TABLE OF CONTENTS**

Definition and Function of Temporary Supports ..... 1

Important matters must be considered before design of temporary supports ..... 1

When Temporary Supports are Used?..... 2

Basic Building Materials..... 2

Example 1: Existing Water Treatment Plant ..... 3

Stringer Design ..... 7

Cap Beam Design ..... 8

Subcap Beam Design..... 8

Case Study: Retrofit Project in San Francisco, California ..... 14

    Project Overview ..... 14

    Bent Cap Replacement ..... 16

    Hinge Replacement..... 17

Conclusion ..... 18

References ..... 20

**LIST OF FIGURES**

Figure 1. Temporary support of an existing structure..... 4

Figure 2. Existing structure schematic drawing..... 4

Figure 3. Water occupying the center cell ..... 5

Figure 4. Plan view of temporary support layout..... 6

Figure 5. Two loading condition options..... 6

Figure 6. Shear and moment diagram method 1 ..... 7

Figure 7. Tower arrangement supporting stringers ..... 9

Figure 8. Cap beam layout, end view section..... 9

Figure 9. Subcap beam layout..... 10

Figure 10. Elevation view of structure ..... 12

Figure 11. Pad load distribution..... 12

Figure 12. Corbel and pad (sill) arrangement..... 13

Figure 13. Coil rod attachment. .... 13

Figure 14. Viaduct schematic—two levels. .... 14

Figure 15. Highway 280 split going over Highway 101 in San Francisco. .... 15

Figure 16. Typical bent cap replacement ..... 16

Figure 17. Hinge support ..... 17

Figure 18. Sketch of hinge replacement ..... 18

**LIST OF TABLES**

Table 1. Lists example calculations of three different materials..... 3

## **Definition and Function of Temporary Supports**

Temporary supports are used in construction when an existing structure requires temporary support during demolition, construction, or retrofitting. The owner of the structure could be concerned about the structure settling, shifting, or completely failing. Sometimes the structures continue to be occupied, such as a building or bridge; and sometimes the facility is completely put out of service during construction. Regardless of the situation, the condition of the structure and safety of the public is most important.

## **Important matters must be considered before design of temporary supports**

During the planning stages for a temporary support design, the contractor must consider, at a minimum, the following:

1. How stiff is the existing structure compared to the stiffness of the temporary support? Can the existing structure allow any deflection or must the temporary support be designed for no deflection?
2. How much does the existing structure weigh?
3. Which portion of the structure footprint will require support?
4. Where can the loads be transferred?
5. Is there sufficient support capability adjacent to the structure?
6. Are temporary piles required?
7. What materials are available?
8. Do the specifications dictate the testing methods for welding and material usage?
9. Is the structure itself, in part, going to be part of the support? And if so, will it be able to stay within its allowable stresses?

10. Does the temporary support system have to be preloaded with a jacking device to eliminate or minimize deflection and stress? If so, how much preload is required?
11. During the construction of temporary supports, and while the support is in service, settlement monitoring is commonly performed to detect any unwanted settlement or lateral movement in excess of the specifications and allowable stresses to the structure.

## **When Temporary Supports are Used?**

Temporary supports could be necessary on a variety of project types, including the following:

1. State and federal highway projects during retrofit work for seismic upgrades.
  2. Building construction in congested areas to prevent undermining and settlement.
  3. Support of utilities during crossing utility installation or junction structure construction.
- These are just a few situations that could require temporary supports.

## **Basic Building Materials**

Structures that may need to be supported usually contain basic building materials that a contractor utilizes every day, including the following:

- 1) Concrete (150 pcf)
- 2) Reinforced concrete (160 pcf)
- 3) Steel (490 pcf or 0.2836 lb per cubic inch)
- 4) Wood with 19% moisture content (33–40 pcf)
- 5) Water (62.4 pcf)

Other materials that a contractor may need to acquire unit weights for are:

1. Drywall
2. Roofing
3. Siding
4. Fiberglass

Material weights are a function of the volume of the material and its unit weight. If a material is a mixture or composite, the conservative approach would be to use the unit weight of the heaviest material and multiply that times the volume. This almost always results in a heavier load than actual, but this is the safest approach. If the volumes of the two different materials can be determined, then a more accurate weight can be determined. Another way to

be more accurate and not too conservative is to weigh the material and a “new” unit weight can be used.

Table 1. Lists example calculations of three different materials

Item	L	W	H	Volume	Unit Weight	Weight (lb)
Unit of 16' long 2 × 4	16'	4'	3'	192 CF	35.0	6750
Steel plate	12	6	1 1/2"	15,552 in <sup>3</sup>	0.2836	4,401
Concrete deadman	4	3	3	36 CF	150.0	5,400

### Example 1: Existing Water Treatment Plant

A water treatment project was undertaken to increase the plant’s capacity. Part of the scope of the work was to add a tank next to an existing building/structure. The close proximity and depth of the new structure made it necessary to excavate adjacent to the existing structure and risk undermining and subsequently damaging the structure. Figure 1 shows the temporary structure in place. The materials being used are steel wide-flange beams (W shapes), 25-k per leg shoring towers (legs are doubled for 50-k capacity), double steel C-channels, high-strength coil rod tension anchors, and associated plates and nuts. The designers, for these cases, must make sound judgment decisions when determining how much the soil underneath the structure will help support or if the soil support should be completely neglected during the design of the temporary support. Many structures within water and wastewater treatment plants have to stay in service during the installation and life of the temporary support. This means water may have to remain within the structure and its weight added to the structure's weight.

The steps necessary for temporary structure supports can follow this simple list:

1-Determine (calculate) the weight of the structure being supported, including any anticipated live loads as well. In this case, part of the structure could be filled with water. See Figures 2 and 3 for schematics of the structure requiring support.



Figure 1. Temporary support of an existing structure

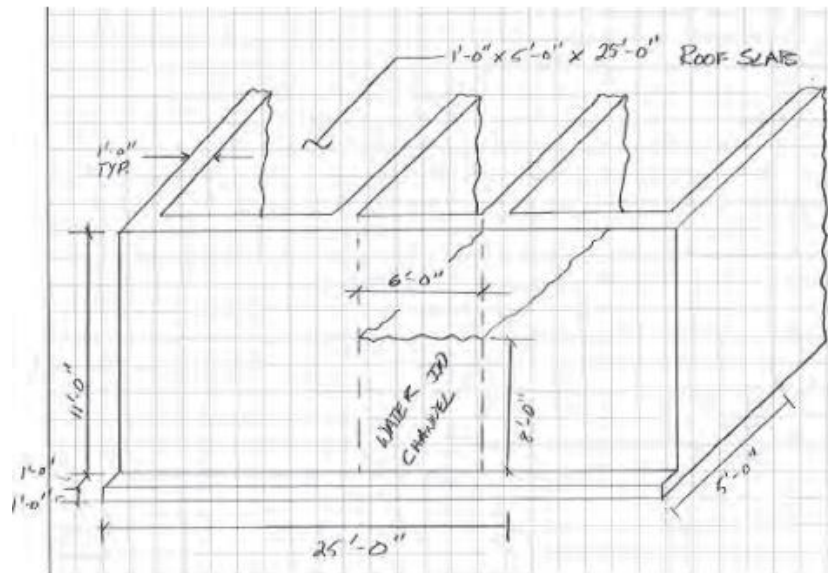

Figure 2. Existing structure schematic drawing

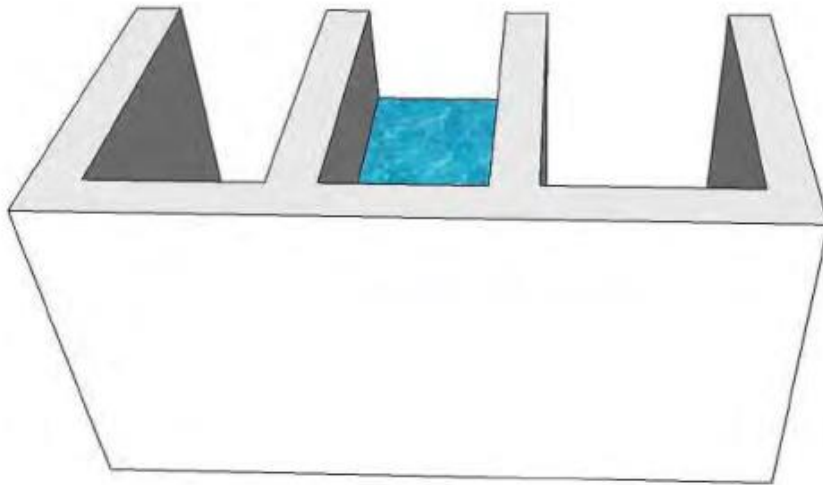

Figure 3. Water occupying the center cell

2-Determine where the structure can be supported. Often these locations can experience high concentrated loads; therefore, the designer must determine what has to happen to the structure to be able to handle the load concentration. Figure 13.3 contains dimensions to assist in weight calculations and locations for support members. This example does not measure the stiffness of the reinforced concrete structure. It is assumed that the structure will be supported at enough points that stiffness is not a concern.

3-Determine what beams can be used and what are the longest spans. The project has W24 × 131's, HP 14 × 89's, and some random, smaller beams available.

Determining Structure Weight Step 1: Determine the weight of the existing structure and associated live loads.

Front Wall:  $(25 \times 11 \times 12'') \times 160 \text{ pcf} = 44,000 \text{ lb}$

Wall 1 Ext (2 ea):  $2(7 \times 11 \times 12'') \times 160 \text{ pcf} = 24,640 \text{ lb}$

Wall 2 Int (2 ea):  $2(7 \times 11 \times 2'') \times 160 \text{ pcf} = 24,640 \text{ lb}$

Slab on grade:  $(25 \times 7 \times 12'') \times 160 \text{ pcf} = 44,000 \text{ lb}$

Water in center cell:  $6 \times 7 \times 8 \times 62.4 \text{ pcf} = 20,966 \text{ lb}$



Total structure weight = 158, 246 lb (160 k)

Weight per linear foot of building (average)  $158.3 \text{ kips}/25 \text{ ft} = 6.4 \text{ klf}$

The layout was conducive to using double stringers. These stringers would be supported by shoring towers on the ground on one side and the existing portion of the structure founded on a lower, stable level on the other side. Figure 4 shows the plan view of this temporary support layout.

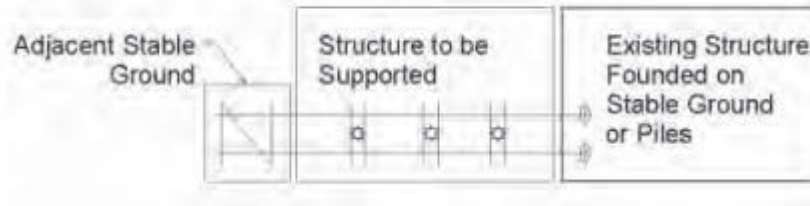

Figure 4. Plan view of temporary support layout

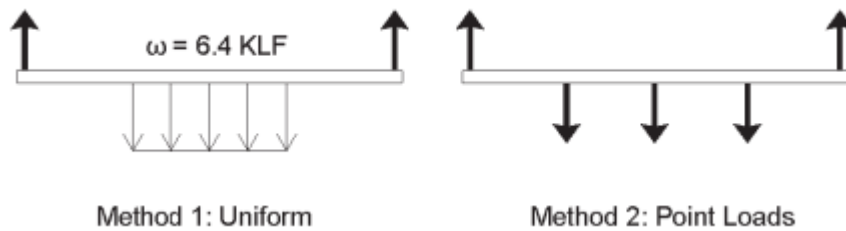

Figure 5. Two loading condition options

The load can be figured as a linear load (6.4 klf) or as three concentrated loads representing each cell (see Figure 5). Regardless of the method, the maximum moment figured should be the worst-case scenario.

Method 1: 6.4 klf (see previous calculation).

Method 2: Four concentrated loads, one from each wall of the three cells. The center cell is heavier due to the water inside the channel.

Method 1 from Beam Software:

$$M_{\max} = 1140 \text{ ft-k}$$

$$V_{\max} = 80 \text{ k}$$

Method 2 from Beam Software:

$$M_{\max} = 1087 \text{ ft-k}$$

$$V_{\max} = 82 \text{ k (loads off center slightly)}$$

## Stringer Design

Using the most conservative method would mean using the moment and shear from method 1 shown in Figure 6. With these values we can check if two W24 × 131 work side by side. For clarity, the weight of the actual beams will not be added to the live loads. In practice, these weights would not be ignored. Allowable stresses for A36 steel:

$$F_b = 0.60F_y = 21.6 \text{ ksi}$$

$$F_v = 0.40F_y = 14.4 \text{ ksi}$$

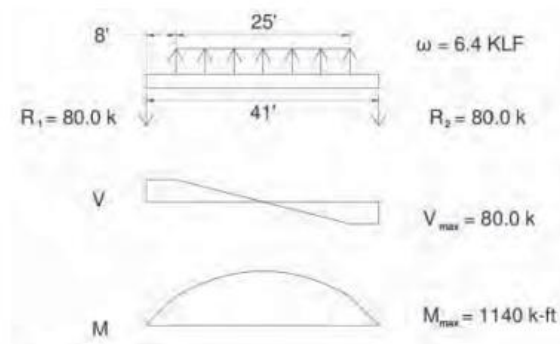

Figure 6. Shear and moment diagram method 1

$S_x$  for a single W24 × 131 = 329 in<sup>3</sup>, two beams  $S_x = 329 \text{ in}^3 \times 2 = 658 \text{ in}^3$

Using method 1:

$$f_b = (1140 \text{ ft-k} \times 12''/\text{ft})/658 \text{ in}^3 = 20.8 \text{ ksi} < 21.6 \text{ ksi (OK)}$$

$$f_v = 82 \text{ k}/2(24.48'' \times 0.605'') = 2.77 \text{ ksi} < 14.4 \text{ ksi (OK)}$$

**Check the stability of the beam** with  $\Delta A_f = 1.98$ .

$20,000 / (36 \times 1.98) = 24.0 < 41$  ft, brace one beam to the other at least in the middle. Two braces would allow the contractor to set the beams as a team and offer more stability.

## Cap Beam Design

The reaction at the tower from the previous beam design is 82 k. This is the force from the double stringer to the HP14 × 89 cap beam. Figure 7 shows the tower arrangement.

The design of the HP14 × 89 cap beam has a double point load from the two W24 × 131's on the HP14 × 89 spanning from one side of the tower to the other side. The two point loads can be combined as one 82-k load in order to simplify the problem and still end up with the same moment. The tower is made up of double frames on each side. They are generally 25 k per leg frames, but, when doubled up, become 50 k per leg towers. The span of the HP14 × 89 is approximately 6 ft. Therefore, using the 82-k load and a 6-ft span, calculate the maximum bending moment in the cap beam as shown in Figure 8. As a rule, the shear should also be checked.

$$M = PL/4$$

$$M = 82 \text{ k} (6 \text{ ft})/4 = 123 \text{ ft-k}$$

$$F_b = 123 \text{ ft-k} \times 12 \text{''/ft} / 131 \text{ in}^3 = 11.27 \text{ ksi} < 21.6 \text{ ksi (OK)}$$

$$F_v = 41 \text{ k} / (13.83 \text{''} \times 0.615 \text{''}) = 4.82 \text{ ksi} < 14.4 \text{ ksi (OK)}$$

## Subcap Beam Design

The subcaps run the short distance of the tower (4 ft), and there are two on each side in order to distribute the cap beam load equally.

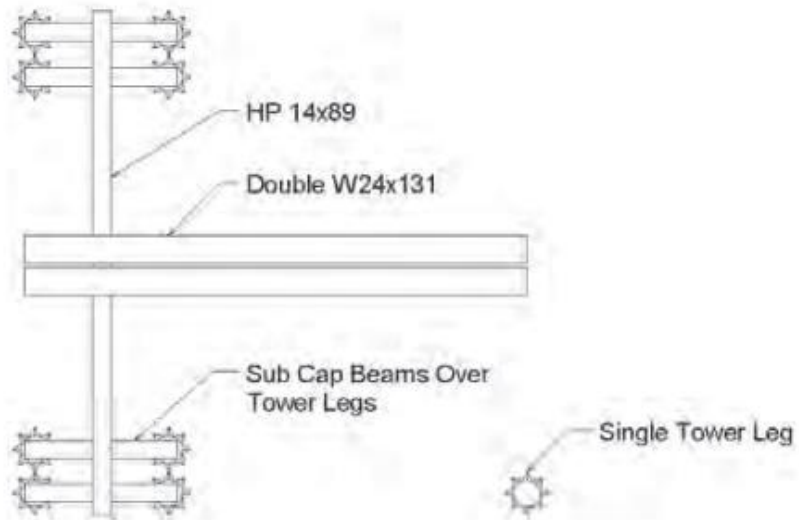

Figure 7. Tower arrangement supporting stringers

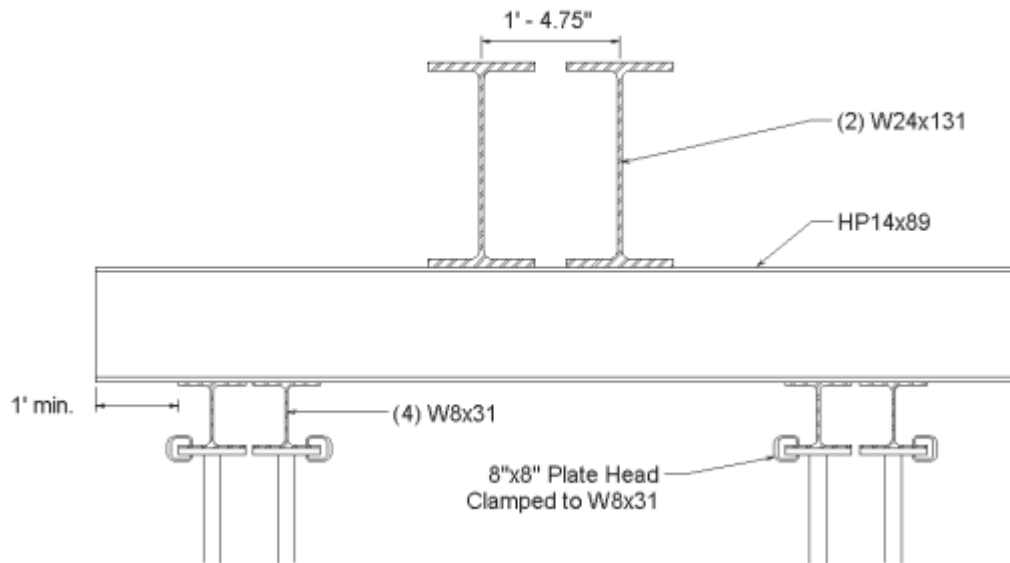

Figure 8. Cap beam layout, end view section

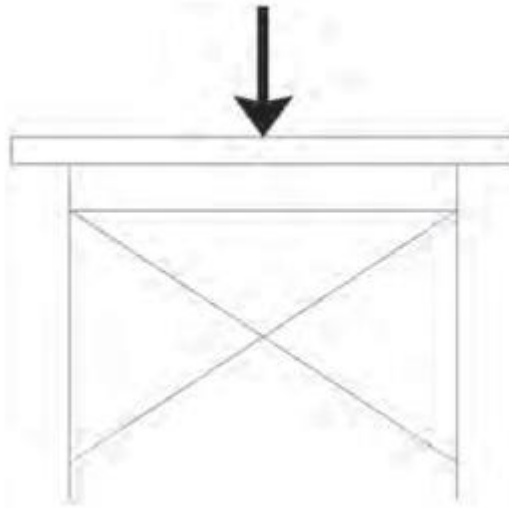

Figure 9. Subcap beam layout

The company has available some short  $W8 \times 31 \times 8'$  beams. Determine if this size beam will be sufficient. Apply the force from the cap beam to the center of the subcap beam similar to Figure 9. There are double subcaps on each side so be sure to divide the total 82-k force by 4. Properties of a  $W8 \times 31$ :

$$S_x = 27.5 \text{ in}^3$$

$$d = 8.0''$$

$$t_w = 0.285''$$

$$M = \frac{PL}{4} \quad M = \frac{(82 \text{ k}/4 \text{ ea})(4 \text{ ft})}{4} = 20.5 \text{ ft-k}$$

$$f_b = \frac{(20.5 \text{ ft-k})(12''/\text{ft})}{27.5 \text{ in}^3} = 8.95 \text{ ksi} < 21.6 \text{ ksi}$$

This is more than half the allowable stress. Would one subcap beam work?

$$f_b = \frac{41 \text{ ft-k} \times 12''/\text{ft}}{27.5 \text{ in}^3} = 17.9 \text{ ksi} < 21.6 \text{ ksi} \quad (\text{OK})$$

A single subcap beam would work. However, the reason a contractor may have used the double tower ( $25 \times 2 = 50$  k) is to be sure the tower capacity is adequate. The next few steps will address the towers.

The tower leg loads come from the total 82-k force to the whole tower. If this 82-k force was distributed equally to the eight tower legs, the force on each leg would be slightly over 10 k. In this case, this falsework system is slightly underused.

$$82 \text{ k} / 8 \text{ legs} = 10.25 \text{ k/leg} < 25 \text{ k (OK)}$$

The foundation for this system could be a series of timber pads distributing the tower leg forces to the soil. The pads must be a safe distance from the top of slope into the excavation. Figure 10 shows the location of the tower supports and the importance of this distance. A pair of two legs are supporting 20.5 k in this example. Figure 10 shows four  $4 \times 6$ 's supporting a  $4 \times 6$  corbel. If the  $4 \times 6$  corbel projects a 1 :1 load path to the supporting soil, what would the soil load be?

$$F = 20.5 \text{ k} / \{(4 \times 5.5") \times [5.5" + (2 \times 3.5)]\} / 144 \text{ in}^2 = 10.73 \text{ ksf or } 10,730 \text{ psf}$$

Besides some rare occasions, soil pressure can support anywhere from 2000 psf to 6000 psf. Therefore, this soil either needs to be supported on imported aggregate fill compacted to 95% or the base dimensions on the corbels and pads need to be widened.



Figure 10. Elevation view of structure

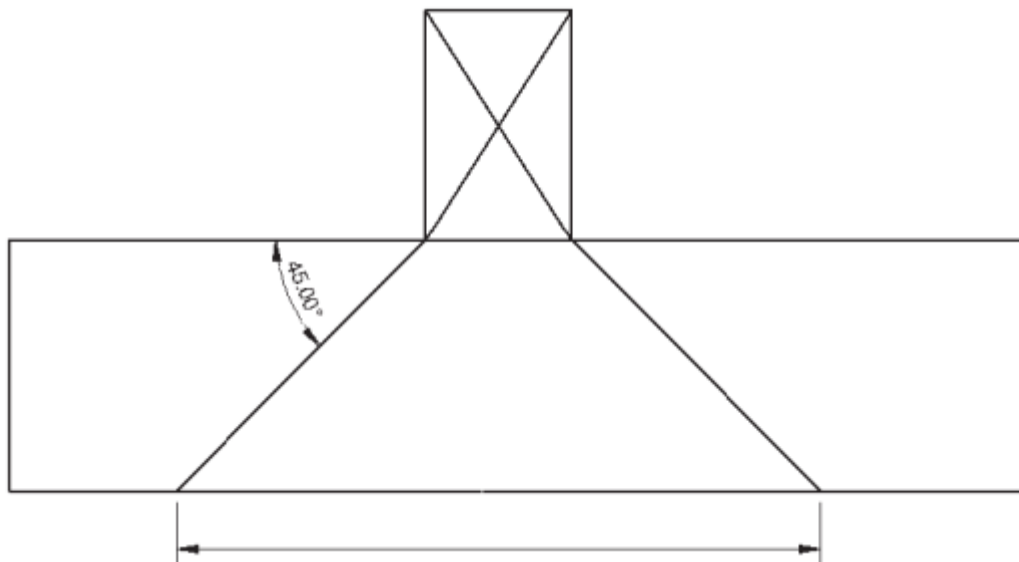

Figure 11. Pad load distribution.

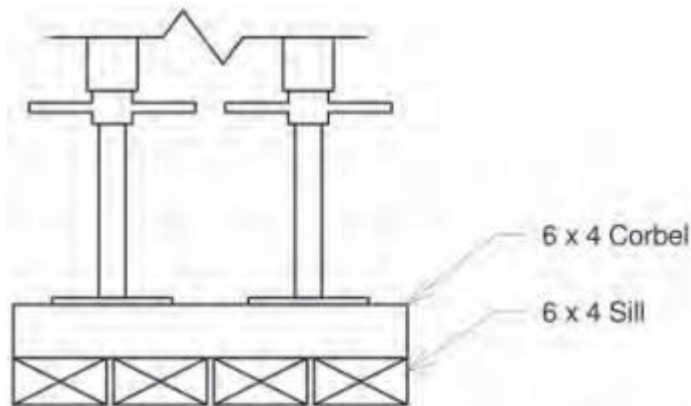

Figure 12. Corbel and pad (sill) arrangement

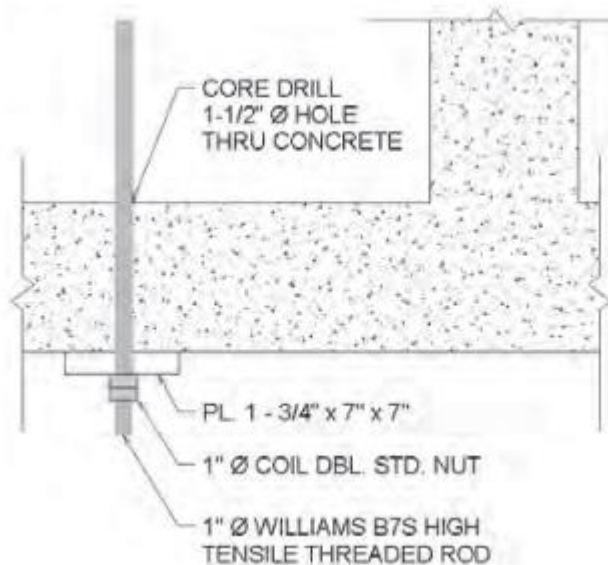

Figure 13. Coil rod attachment.

The projection of the load through the timber pads is illustrated in Figure 11. Figure 12 shows the actual design condition of the corbels and pads (sills). The two beams are attached to the structure with coil rods, plates, and nuts (see Figure 13). The coil rod capacity should be adequate to resist the weight of the portion of structure associated with the rod location. In this case, four rods are proposed. If we go back to the method 2 case for the stringer



design, the two center rods were estimated to hold 30 k at the two outside rods and 50 k at the two inside rods. If the system was designed to support the 50-k load, then the other rods would be more than adequate. Of course, the two scenarios could have different rod diameters, but then the project staff would have to inventory these rods, and the chance of placing the wrong rod in the wrong location would increase. The Williams coil rod that has minimum yield strength of 58.1 k is the 1.25" diameter coil rod.

## **Case Study: Retrofit Project in San Francisco, California**

### **Project Overview**

After the Loma Prieta earthquake shook northern California in 1989, a decade of projects were initiated, including projects that widened and reinforced footings, wrapped columns in steel jackets, and replaced complete substructures. Such projects were something of the norm from 1990 to almost 2000. Many heavy civil contractors who did not want to miss out on an opportunity to contract in a new kind of work began to bid and build many of these retrofit projects.

Since this work was fairly new, it brought not only new, exciting projects to the workplace but also a significant amount of uncertainty. What used to be considered normal ways to build bridges and their components was being changed. Even the California Department of Transportation had to develop standards and best practices for contractors to follow. The welding code previously used for temporary structures was changed to include welding procedures normally used for permanent structures. Figure 14 shows a schematic of a typical viaduct structure with two levels.

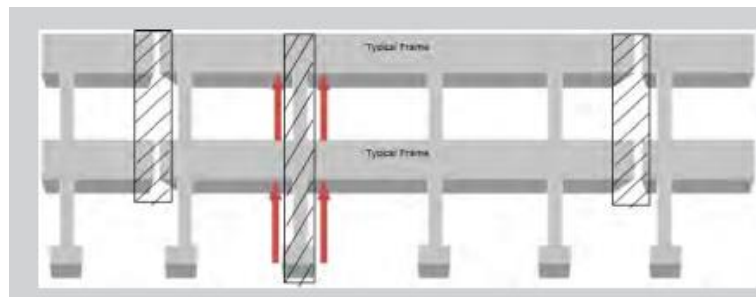

*Figure 14. Viaduct schematic—two levels.*

During this period, one structure of concern (following the collapse of a two-story bridge in Oakland) was a viaduct that spanned Silver Ave and Highway 101 and merged onto the Highway 280 corridor in San Francisco. This viaduct, originally constructed in the early 1960s, had sections that were constant but also had sections that were unique. Figure 15 shows a portion of Highway 280 going over Highway 101. The main purpose of this project was to support the existing reinforced concrete box-girder bridge; remove the footings, columns, and portions of the bent caps; install new piles, columns, and bent caps; and construct a longitudinal edge beam along each side of the lower deck portion. The project was sequenced (by specification) so that no adjacent bents could be worked on within a single frame. A frame on this project (hinge to hinge) consisted of approximately three to four bent caps. The bridge in most cases was two levels, and the lanes on the two levels were mostly closed to traffic for the duration of the project. In addition to the retrofitted bent caps, several hinges were removed completely (edge of deck to edge of deck) and rebuilt with new, state-of-the-art spherical Teflon bearings. While the hinge was removed, the bridge had to be supported back to the closest bent cap (the short span) while supporting the long span.

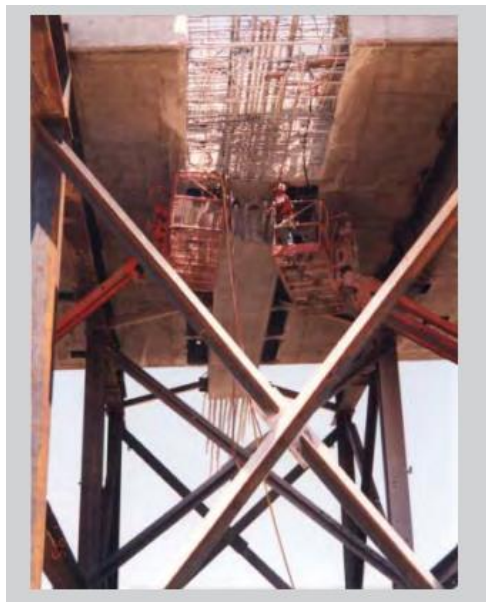

*Figure 15. Highway 280 split going over Highway 101 in San Francisco.*

### **Bent Cap Replacement**

There were 5 frames with a total of 23 bents (approximately 4 to 5 bents per frame). As mentioned earlier, only one bent per frame could be retrofitted at once. In other words, only 5 bents could be worked on at the same time. Also, 2 adjacent bents could not be worked on simultaneously. In addition to these constraints, other specification constraints made it so there were actually only 4 bents being worked on simultaneously. As the project moved forward, partnering efforts allowed more work to be accomplished at the same time but never enough to satisfy an aggressive schedule.

The image shown in Figure 16 was a typical bent cap retrofit. The bridge was supported by temporary supports on each side of the bent cap. The temporary supports were spaced far enough apart to allow access to the demolition and structures crew while at the same time not increasing the tributary load that had to be supported. The supports consisted of WF posts, WF beams, T shape bracing, and was founded on temporary piling in most cases. Hydraulic jacks and short beams were used between the bottom of the bridge and the top of the main beam. The system was jacked to a prescribed load, and then beam spacers were placed until the system was de-stressed and removed.



*Figure 16. Typical bent cap replacement*

The demolition consisted of concrete removal where shown on the drawings and in almost all cases required the reinforcing steel to remain. The limits of box-girder removal were limited to 2 ft on each side of the bent cap, which would be replaced by additional new bent cap concrete (8 ft). The original bent caps were 4 ft wide. The reinforcing bar placement was difficult and couplers were used extensively to join the new bars to the old, remaining bars. In new construction, the ironworkers can determine the order of bar placement in the most economical fashion. In retrofit construction, where existing bars remain, the order of placement is somewhat dictated by the remaining bars. It should also be pointed out that every operation had to work around the temporary supports on each side of the bent.

Welding was critical on this project. The owner specified very strict welding requirements that would normally be used for new construction, and welder certifications were time consuming and expensive. Most of the welding was performed on-site so it took a while to get the on-site welding operations to run as smoothly as a shop might perform. In most cases, this goal was not reached.

### **Hinge Replacement**

During the hinge replacement, the complete hinge, including concrete and reinforcing steel (except approximately 4 ft of reinforcing on each side), was removed. The bridge was approximately 40 ft wide and about 20 ft of hinge was removed longitudinally. The temporary support system selected doubled as a demolition platform and as support for the new concrete to be placed. The above deck support beams spanned from one bent to close to another bent since the removal took away any possibility that the bridge itself could offer any support. The work on the new hinge took approximately 2 months until the temporary support could be removed. Figure 17 shows a hinge support in place and the existing hinge concrete removed.



*Figure 17. Hinge support*

The above deck beams were W36 beams and were capped at the locations where the support rods went through the deck and were also diagonally braced. The support rods went through holes that were drilled into the top and bottom deck of the box girder and terminated under the bridge with plates and nuts. The rods were 1.25 " and 1.5 " Dywidag type with 150-ksi high-strength capacity. The falsework deck/demo platform was also supported by these rods. The new hinge was built in four stages of concrete placements and included the new bearing installation. The demolition was done either with small machines or by hand to preserve the remaining concrete and reinforcing steel. The specifications were very strict on not damaging the reinforcing steel that was to remain; and if damage did occur, the bars had to be fill-welded with welding rod. Figure 18 is a sketch of a typical hinge support and how the loads were transferred to each adjacent bridge bent.

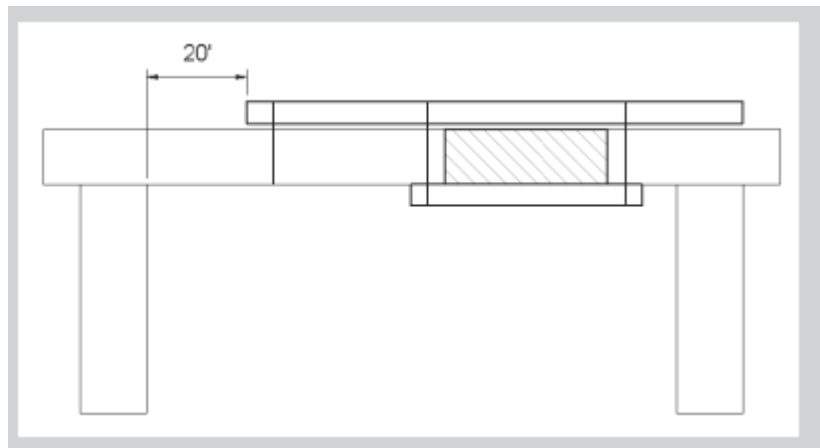

*Figure 18. Sketch of hinge replacement*

## **Conclusion**

The previous example in this course represents more challenging and unusual temporary support situations.

The case study discussed may be more representative of temporary support situations that one may encounter in heavy civil construction. Whatever the situation, contractors should procure the services of a qualified, registered, licensed engineer to assist in a safe and economical design and to distribute some unnecessary risk. The student of temporary structure design should be proficient in calculating weights of all materials knowing the overall dimensions and

unit weights of the materials. With these basic skills, one should be able to assist in any temporary structure supporting existing structures, buildings, and utilities.

## **References**

1. Temporary Structures Standard, Australian Building Codes Board ,ABCB, 2015
2. Robert T. Ratay, “Temporary Structures in Construction”, Text Book, McGraw-Hill Companies, 2012
3. Robert Beale & João André, “ Design Solutions and Innovations in Temporary Structures”, Text Book, IGI Global, 2017.